

GEARMOTOR
FOR SWING GATES

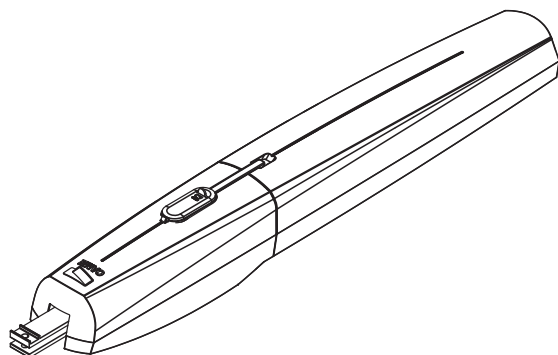

FA00021-EN



Official Partner



MILANO 2015
FEEDING THE PLANET
ENERGY FOR LIFE



AXI

Installation manual
SWN20 - SWN25

EN English



WARNING!
Important safety instructions for people:
READ CAREFULLY!



FOREWORD

- THIS PRODUCT MUST ONLY BE USED FOR ITS INTENDED PURPOSE. ANY OTHER USE IS DANGEROUS. CAME S.P.A. IS NOT LIABLE FOR ANY DAMAGE CAUSED BY IMPROPER, WRONGFUL AND UNREASONABLE USE
- KEEP THESE WARNINGS TOGETHER WITH THE INSTALLATION AND OPERATION MANUALS THAT COME WITH THE GEARMOTOR.

BEFORE INSTALLING

(CHECKING WHAT'S THERE: IF YOUR EVALUATION IS NEGATIVE, DO NOT PROCEED BEFORE HAVING COMPLIED WITH ALL SAFETY REQUIREMENTS)

- CHECK THAT THE AUTOMATED PARTS ARE IN GOOD MECHANICAL ORDER, THAT THE GEARMOTOR IS LEVEL AND ALIGNED, AND THAT IT OPENS AND CLOSES PROPERLY. MAKE SURE YOU HAVE SUITABLE MECHANICAL STOPS
- IF THE GEARMOTOR IS TO BE INSTALLED AT A HEIGHT OF OVER 2.5 M FROM THE GROUND OR OTHER ACCESS LEVEL, MAKE SURE YOU HAVE ANY NECESSARY PROTECTIONS AND/OR WARNINGS IN PLACE
- IF ANY PEDESTRIAN OPENINGS ARE FITTED INTO THE GEARMOTOR, THERE MUST ALSO BE A SYSTEM TO BLOCK THEIR OPENING WHILE THEY ARE MOVING
- MAKE SURE THAT THE OPENING AUTOMATED DOOR OR GATE CANNOT ENTRAP PEOPLE AGAINST THE FIXED PARTS OF THE GEARMOTOR
- DO NOT INSTALL THE GEARMOTOR UPSIDE DOWN OR ONTO ELEMENTS THAT COULD YIELD AND BEND. IF NECESSARY, ADD SUITABLE REINFORCEMENTS TO THE ANCHORING POINTS
- DO NOT INSTALL DOOR OR GATE LEAVES ON TILTED SURFACES
- MAKE SURE ANY SPRINKLER SYSTEMS CANNOT WET THE GEARMOTOR FROM THE GROUND UP
- MAKE SURE THE TEMPERATURE RANGE SHOWN ON THE PRODUCT LITERATURE IS SUITABLE TO THE CLIMATE WHERE IT WILL BE INSTALLED
- FOLLOW ALL INSTRUCTIONS AS IMPROPER INSTALLATION MAY RESULT IN SERIOUS BODILY INJURY
- IT IS IMPORTANT TO FOLLOW THESE INSTRUCTIONS FOR THE SAFETY OF PEOPLE. KEEP THESE INSTRUCTIONS.

INSTALLING

- SUITABLY SECTION OFF AND DEMARCATÉ THE ENTIRE INSTALLATION SITE TO PREVENT UNAUTHORIZED PERSONS FROM ENTERING THE AREA, ESPECIALLY MINORS AND CHILDREN
- BE CAREFUL WHEN HANDLING GEARMOTORS THAT WEIGH OVER 20 KG. IF NEED BE, USE PROPER SAFETY HOISTING EQUIPMENT
- ALL OPENING COMMANDS (THAT

IS, BUTTONS, KEY SWITCHES, MAGNETIC READERS, AND SO ON) MUST BE INSTALLED AT LEAST 1.85 M FROM THE PERIMETER OF THE GATE'S WORKING AREA, OR WHERE THEY CANNOT BE REACHED FROM OUTSIDE THE GATE. ALSO, ANY DIRECT COMMANDS (BUTTONS, TOUCH PANELS, AND SO ON) MUST BE INSTALLED AT LEAST 1.5 M FROM THE GROUND AND MUST NOT BE REACHABLE BY UNAUTHORIZED PERSONS- ALL MAINTAINED ACTION COMMANDS, MUST BE FITTED IN PLACES FROM WHICH THE MOVING GATE LEAVES AND TRANSIT AND DRIVING AREAS ARE VISIBLE
- APPLY, IF MISSING, A PERMANENT SIGN SHOWING THE POSITION OF THE RELEASE DEVICE
- BEFORE DELIVERING TO THE USERS, MAKE SURE THE SYSTEM IS EN 12453 STANDARD COMPLIANT (REGARDING IMPACT FORCES), AND ALSO MAKE SURE THE SYSTEM HAS BEEN PROPERLY ADJUSTED AND THAT ANY SAFETY, PROTECTION AND MANUAL RELEASE DEVICES ARE WORKING PROPERLY
- APPLY WARNING SIGNS (SUCH AS THE GATE'S PLATE) WHERE NECESSARY AND IN A VISIBLE PLACE

SPECIAL USER-INSTRUCTIONS AND RECOMMENDATIONS

- KEEP GATE OPERATION AREAS CLEAN AND FREE OF ANY OBSTRUCTIONS. MAKE SURE THAT THE PHOTOCELLS ARE FREE OF ANY OVERGROWN VEGETATION AND THAT THE GEARMOTOR'S AREA OF OPERATION IS FREE OF ANY OBSTRUCTIONS
- DO NOT ALLOW CHILDREN TO PLAY WITH FIXED COMMANDS, OR TO LOITER IN THE GATE'S MANEUVERING AREA. KEEP ANY REMOTE CONTROL TRANSMITTERS OR ANY OTHER COMMAND DEVICE AWAY FROM CHILDREN, TO PREVENT THE GEARMOTOR FROM BEING ACCIDENTALLY ACTIVATED.
- THE APPARATUS MAY BE USED BY CHILDREN OF EIGHT YEARS AND ABOVE AND BY PHYSICALLY, MENTALLY AND SENSORIALLY CHALLENGED PEOPLE, OR EVEN ONES WITHOUT ANY EXPERIENCE, PROVIDED THIS HAPPENS UNDER CLOSE SUPERVISION OR ONCE THEY HAVE BEEN PROPERLY INSTRUCTED TO USE THE APPARATUS SAFELY AND ABOUT THE POTENTIAL HAZARDS INVOLVED. CHILDREN MUST NOT PLAY WITH THE APPARATUS. CLEANING AND MAINTENANCE BY USERS MUST NOT BE DONE BY CHILDREN, UNLESS PROPERLY SUPERVISED
- FREQUENTLY CHECK THE SYSTEM FOR ANY MALFUNCTIONS OR SIGNS OF WEAR AND TEAR OR DAMAGE TO THE MOVING STRUCTURES, TO THE COMPONENT PARTS, ALL ANCHORING POINTS, INCLUDING CABLES AND ANY ACCESSIBLE CONNECTIONS. KEEP ANY HINGES, MOVING



JOINTS AND SLIDE RAILS PROPERLY LUBRICATED • PERFORM FUNCTIONAL CHECKS ON THE PHOTOCELLS AND SENSITIVE SAFETY EDGES, EVERY SIX MONTHS. TO CHECK WHETHER THE PHOTOCELLS ARE WORKING, WAVE AN OBJECT IN FRONT OF THEM WHILE THE GATE IS CLOSING; IF THE GEARMOTOR INVERTS ITS DIRECTION OF TRAVEL OR SUDDENLY STOPS, THE PHOTOCELLS ARE WORKING PROPERLY. THIS IS THE ONLY MAINTENANCE OPERATION TO DO WITH THE POWER ON. CONSTANTLY CLEAN THE PHOTOCELLS' GLASS COVERS USING A SLIGHTLY WATER-MOISTENED CLOTH; DO NOT USE ANY SOLVENTS OR OTHER CHEMICAL PRODUCTS THAT MAY RUIN THE DEVICES • IF REPAIRS OR MODIFICATIONS ARE REQUIRED TO THE SYSTEM, RELEASE THE GEARMOTOR AND DO NOT USE IT UNTIL SAFETY CONDITIONS HAVE BEEN RESTORED • CUT OFF THE POWER SUPPLY BEFORE RELEASING THE GEARMOTOR FOR MANUAL OPENINGS AND BEFORE ANY OTHER OPERATION, TO PREVENT POTENTIALLY HAZARDOUS SITUATIONS. READ THE INSTRUCTIONS • IF THE POWER SUPPLY CABLE IS DAMAGED, IT MUST BE REPLACED BY THE MANUFACTURER OR AUTHORIZED TECHNICAL ASSISTANCE SERVICE, OR IN ANY CASE, BY SIMILARLY QUALIFIED PERSONS, TO PREVENT ANY RISK • IT IS FORBIDDEN FOR USERS TO PERFORM ANY OPERATIONS THAT ARE NOT EXPRESSLY REQUIRED OF THEM AND WHICH ARE NOT LISTED IN THE MANUALS. FOR ANY REPAIRS, MODIFICATIONS AND ADJUSTMENTS AND FOR EXTRAORDINARY MAINTENANCE, CALL TECHNICAL ASSISTANCE • LOG THE JOB AND CHECKS INTO THE PERIODIC MAINTENANCE LOG.

ADDITIONAL SPECIAL RECOMMENDATIONS FOR EVERYONE

- KEEP AWAY FROM HINGES AND MECHANICAL MOVING PARTS
- DO NOT ENTER THE GEARMOTOR'S AREA OF OPERATION WHEN IT IS MOVING
- DO NOT COUNTER THE GEARMOTOR'S MOVEMENT AS THIS COULD RESULT IN DANGEROUS SITUATIONS
- ALWAYS PAY SPECIAL ATTENTION TO ANY DANGEROUS POINTS, WHICH HAVE TO BE LABELED WITH SPECIFIC PICTOGRAMS AND/OR BLACK AND YELLOW STRIPES
- WHILE USING A SELECTOR SWITCH OR A COMMAND IN MAINTAINED ACTIONS, KEEP CHECKING THAT THERE ARE NO PERSONS WITHIN THE OPERATING RANGE OF ANY MOVING PARTS, UNTIL THE COMMAND IS RELEASED
- THE GATE MAY MOVE AT ANY TIME AND WITHOUT WARNING
- ALWAYS CUT OFF THE POWER SUPPLY BEFORE PERFORMING ANY MAINTENANCE OR CLEANING.



LEGEND

-  This symbol shows which parts to read carefully.
-  This symbol shows which parts describe safety issues
-  This symbol shows which parts to tell users about.

REFERENCE REGULATIONS

Came S.p.A. is certified for the: ISO 9001 quality and ISO 14001 environmental management systems.
This product complies with the current regulations mentioned in the declaration of conformity.

DESCRIPTION

Encoder-fitted irreversible gearmotor for swing gates.
Aluminium and ABS cover, worm screw based reduction system, crown and conical torque.

Intended use

This gearmotor is designed to power and operate swing gates in private homes and apartment blocks.

 Any installation other than what is detailed in this manual is prohibited.

Limits to use

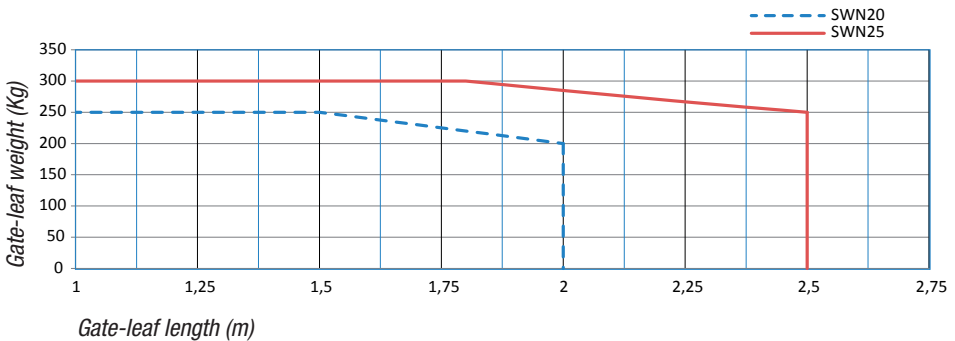

It always advisable to fit an electric lock on swing gates. It makes for a more reliable closure.

Technical data

| Type | SWN20 | SWN25 |
|---|-------|------------|
| Protection rating (IP) | | 44 |
| Control panel power supply (V - 50/60 Hz) | | 230 AC |
| Power supply motor (V) | | 24 DC |
| Max draw (A) | | 5 |
| Maximum power (W) | | 120 |
| Duty cycle (%) | | 50 |
| Opening time at 90° (s) | | 15* |
| Operating temperature (°C) | | -20 ÷ +55 |
| Insulation class | | 3 |
| Reduction ration (i) | | 1/36 |
| Thrust (N) | | 400 ÷ 2000 |
| Weight (Kg) | 5.5 | 6 |

* Smallest reference value with fastest travel and slowest slow-down speeds. The weight and type of door, the gate's state of wear-and-tear and the geography can all vary the value.

Dimensions (mm)

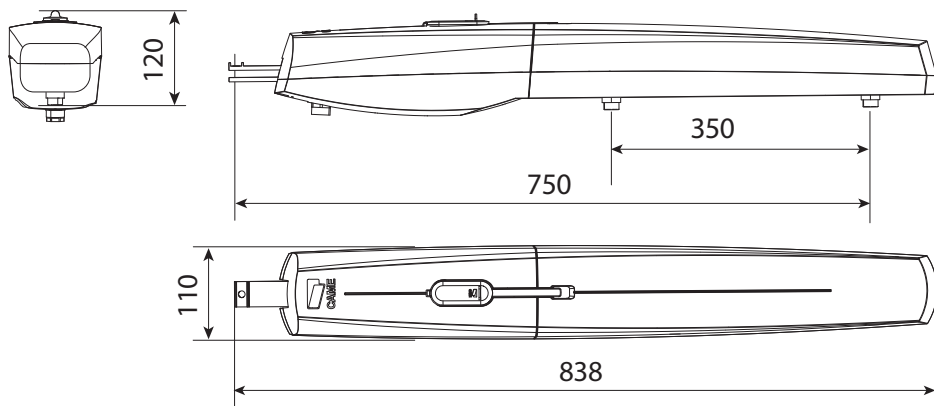

Description of parts

1. Gearmotor
2. Gate bracket and fastening screw
3. Post bracket and fastening screw
4. Bushing for post bracket
5. Release key
6. Cover 1
7. Cover 2

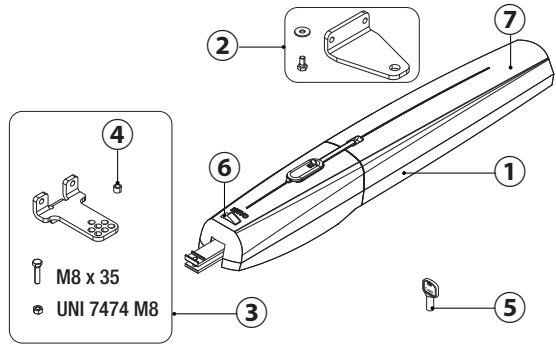

Standard installation

1. Gearmotor
2. Control panel
3. Transmitter
4. Key-switch selector
5. Flashing light
6. Photocells
7. Junction pit
8. Mechanical gate stops

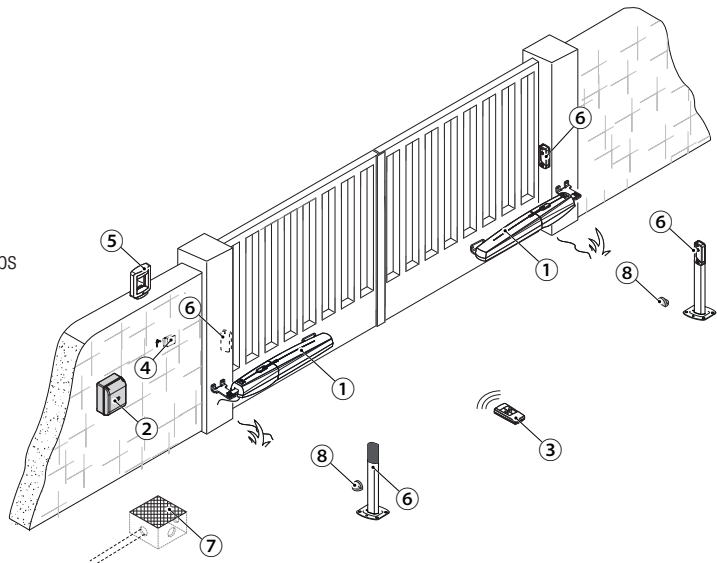

GENERAL INSTRUCTIONS FOR INSTALLING

Only skilled, qualified staff must install this product.

Preliminary checks

⚠ Before beginning, do the following:

- check that the gate is stable and that the hinges are in good working order and lubricated;
- check that distance C does not exceed the reference-table value;
- make sure there are opening and closing mechanical gate stops;
- make sure that the point where the gearmotor is fastened is protected from any impacts and that the surface is solid enough.
- make sure you have set up a suitable dual-pole cut off device along the power supply that is compliant with the installation rules. It should completely cut off the power supply according to category III surcharge conditions (that is, with minimum contact openings of 3 mm);
- ⊕ make sure that any connections inside the container (ones that ensure continuity to the protection circuit) are fitted with additional insulation with respect to those of other electrical parts inside;
- set up suitable tubes and conduits for the electric cables to pass through, making sure they are protected from any mechanical damage.

Tools and materials

Make sure you have all the tools and materials you will need for installing in total safety and in compliance with applicable regulations. The figure shows some of the equipment installers will need.

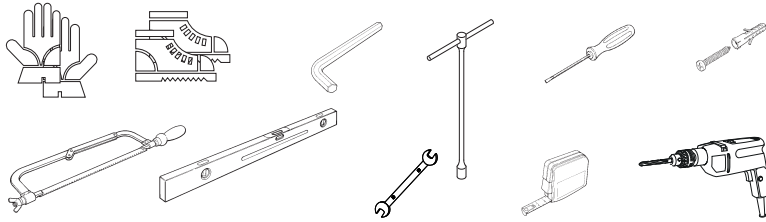

Cable types and minimum thicknesses

| Connection | Cable type | Cable length 1 < 10 m | Cable length 10 < 20 m | Cable length 20 < 30 m |
|-------------------------------------|--|--------------------------|---------------------------|---------------------------|
| Control panel power supply 230 V AC | FROR CEI 20-22 CEI EN 50267-2-1 | 3G x 1.5 mm ² | 3G x 2.5 mm ² | 3G x 4 mm ² |
| Motor power supply 24 V DC | | 3 x 1 mm ² | 3 x 1.5 mm ² | 3 x 2.5 mm ² |
| Flashing light | | 2 x 0.5 mm ² | 2 x 1 mm ² | 2 x 1.5 mm ² |
| Photocell transmitters | | 2 x 0.5 mm ² | 2 x 0.5 mm ² | 2 x 0.5 mm ² |
| Photocell receivers | | 4 x 0.5 mm ² | 4 x 0.5 mm ² | 4 x 0.5 mm ² |
| Command and safety device | | 2 x 0.5 mm ² | 2 x 0.5 mm ² | 2 x 0.5 mm ² |
| Antenna | The RG58 antenna | max 10 m | | |

If cable lengths differ from those specified in the table, establish the cable sections depending on the actual power draw of the connected devices and according to the provisions of regulation CEI EN 60204-1. For multiple, sequential loads along the same line, the dimensions on the table need to be recalculated according to the actual power draw and distances. For connecting products that are not contemplated in this manual, see the literature accompanying said products

INSTALLATION

The following illustrations are mere examples in that the space for anchoring the gearmotor and accessories varies depending on the installation area. It is up to the installer to find the most suitable solution.

Laying the corrugated tubes

Set up the junction boxes and corrugated tubes you will need to make connections coming from the junction pit. To connect the gearmotor we suggest a $\varnothing 60$ mm corrugated tube. Whereas for the accessories we suggest $\varnothing 25$ mm tubes.

 The number of tubes depends on the type of system and the accessories you are going to fit.

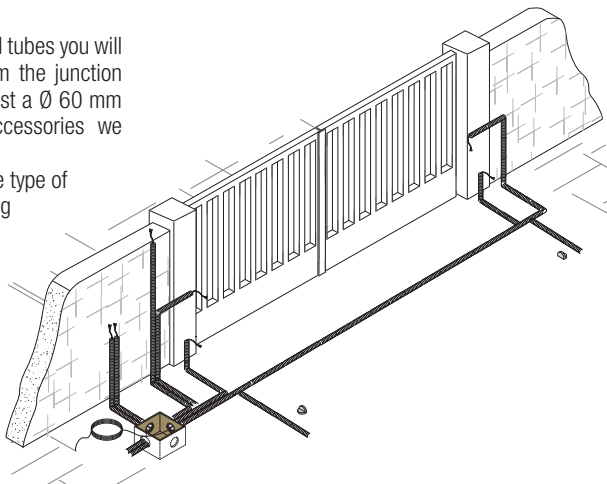

Fastening the brackets

Establish the gate bracket fastening point and find the bracket's fastening point to the post, while respecting the quotas shown in the drawings and tables.

| Opening (°) | A | B | C (mm) | E |
|-------------|-----|-----------|--------|-----|
| 90 | 130 | 110 ÷ 170 | 0 ÷ 60 | 750 |
| 115 | 150 | 110 ÷ 160 | 0 ÷ 50 | 750 |

△ The greater the gate leaf's opening angle, the greater the opening speed and the slower is the gearmotor's thrust. The smaller the gate leaf's opening angle, the slower the opening speed and the greater is the gearmotor's thrust.

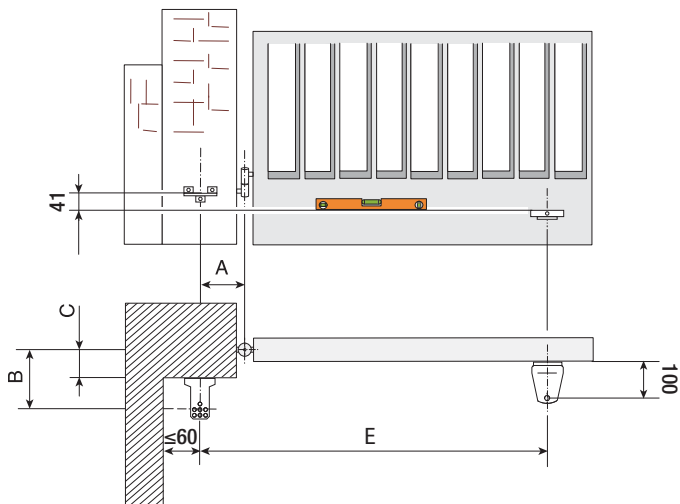

Fasten the bracket to the post **1** using suitable anchors and screws. If the post is made of metal, the bracket can be welded to it.

Note: the holes on the bracket are for further opening angle variations of the gate leaf.

Fasten or weld the bracket to the gate **2**.

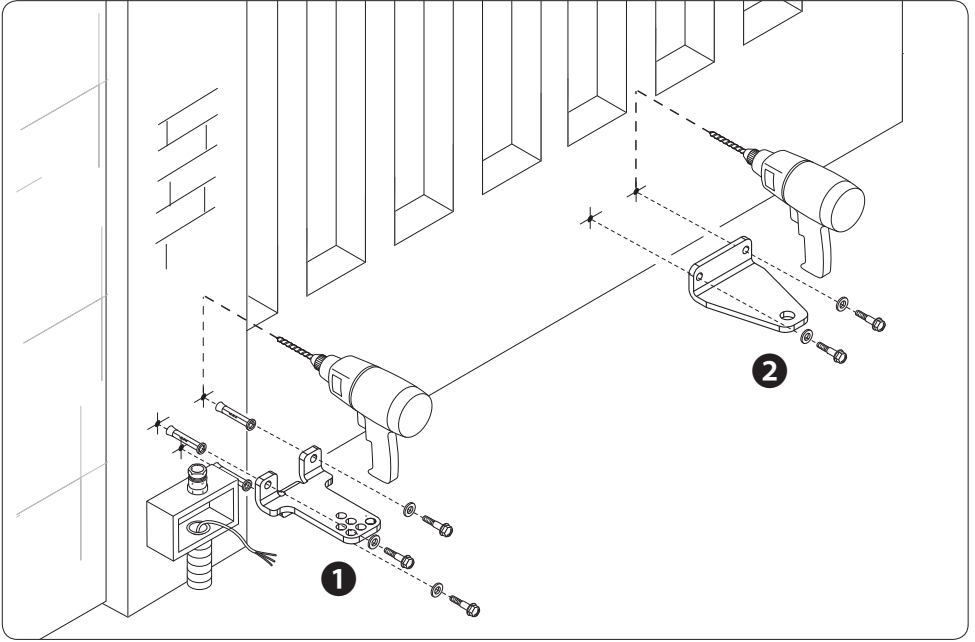

Fastening the gearmotor

Lubricate the bushing **a** and fit it into one of the holes on the post bracket.

Fasten the joint to the post bracket **b** using the M8 x 35 bolt and UNI 7474 M8 nut.

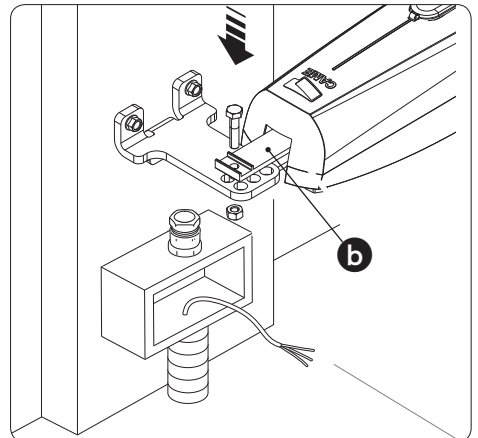
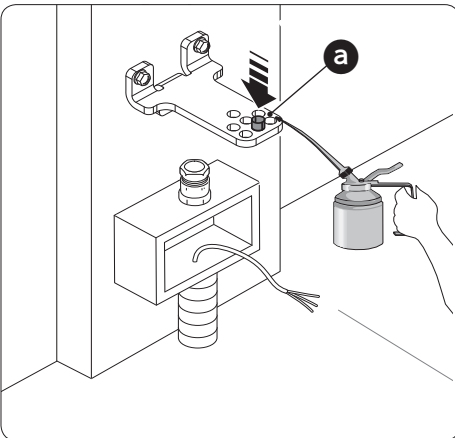

Open the gate leaf (the grub screws on the mechanical stops are loose) and fit the pin **a** into the gate bracket. Fasten using the UNI6593 washer \varnothing 10 and the supplied UNI 5739 M10 X 10 bolt **b**.

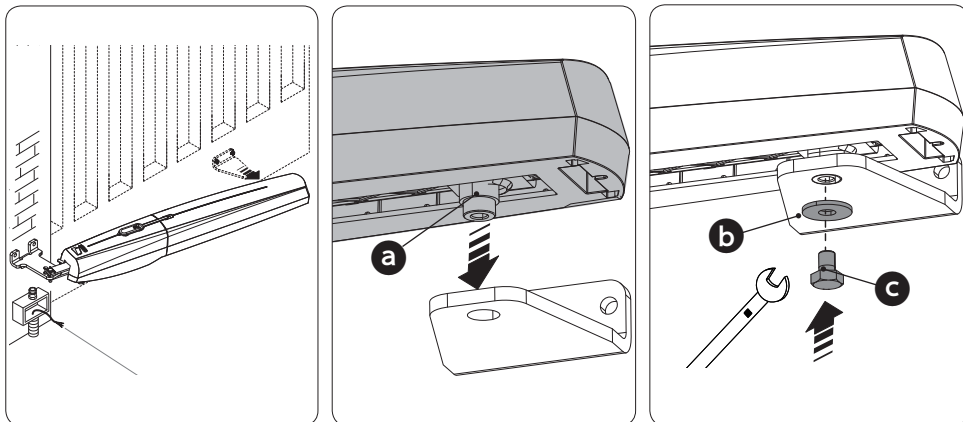

Establishing the limit-switch points

Before establishing the endstop points, you need to: release the gearmotor (see paragraph on manually releasing it) and remove covers 1 and 2 while carefully following the illustrations.

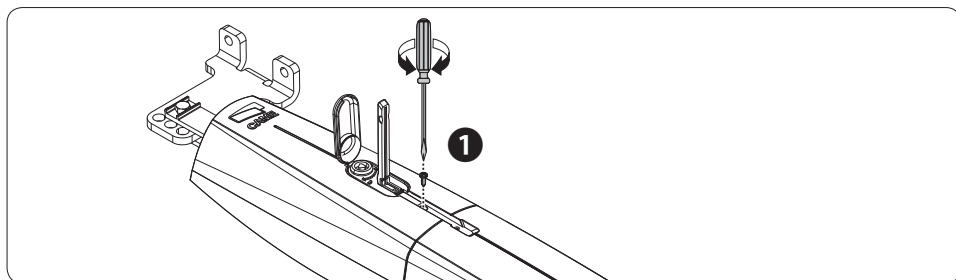

⚠ DO NOT REMOVE cover 1 without first sliding it.

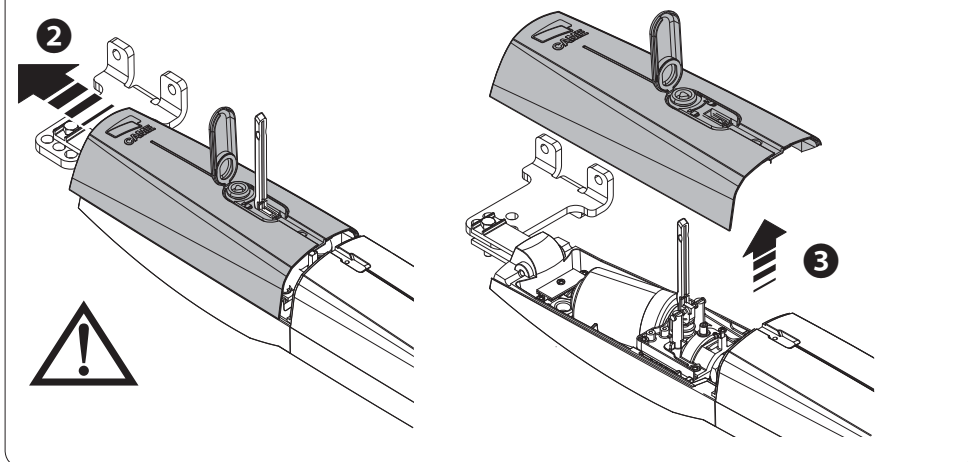

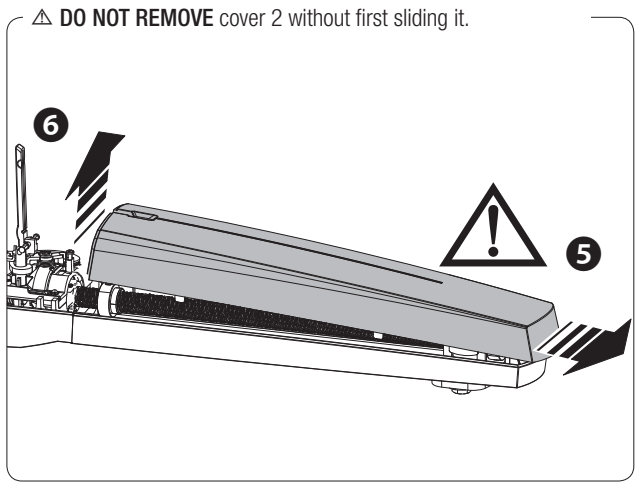
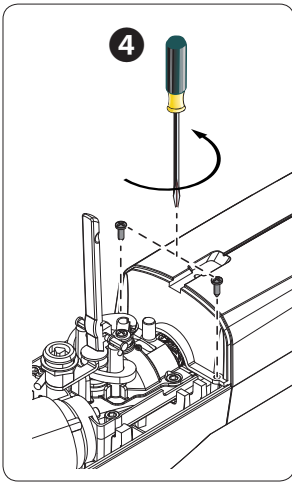

⚠ **DO NOT REMOVE** cover 2 without first sliding it.

For opening

Reach the gate leaf opening point you want and take the mechanical stop to rest using the slide guide. Fasten the closing mechanical stop's grub screws

a.

For closing

Close the gate leaf completely and rest it against the mechanical stop using the slide guide. Fasten the closing mechanical stop's grub screws **b.**

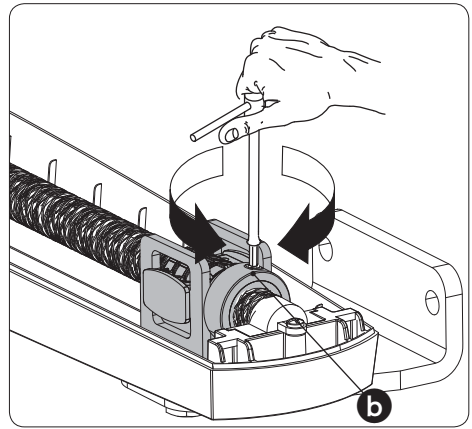
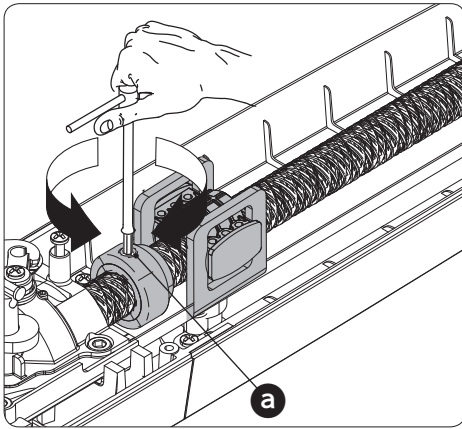

CONNECTIONS TO THE CONTROL PANEL

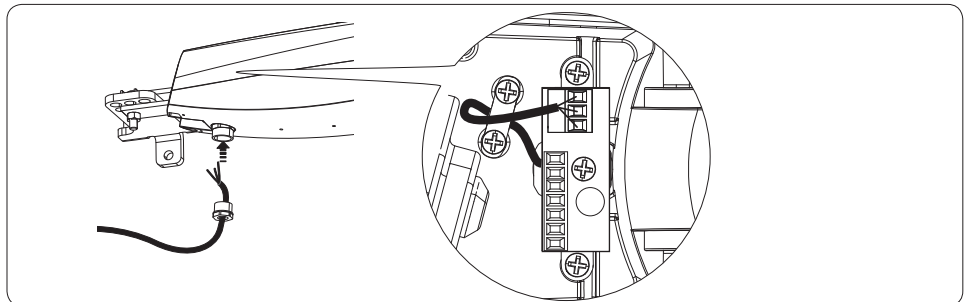

Connecting two gearmotors

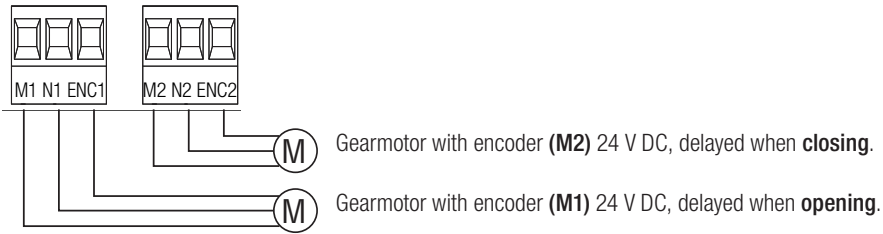

Connecting one gearmotor

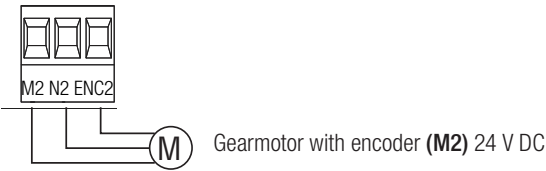

Connection for opening outwards

△ Establish the quotas **A** and **B**.

Cut and fasten post bracket **a** by supplementing it with an additional bracket **b** (not issued).

Open the gate (max 90°), establish the quota **E** and establish the gate bracket fastening point. Fasten the bracket.

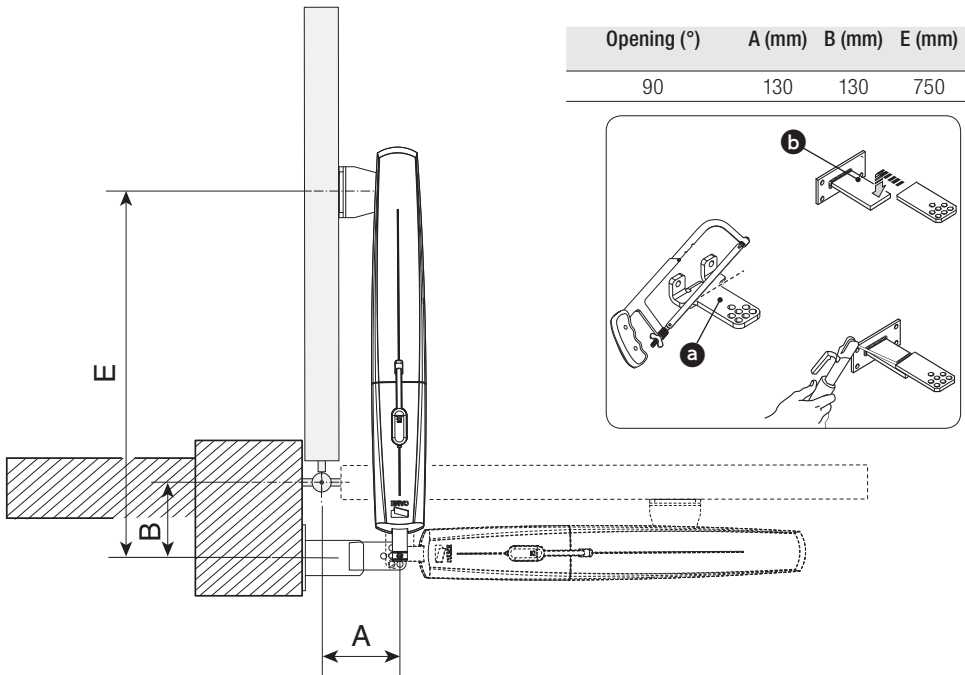

Make the necessary electrical connections as shown in the figure.

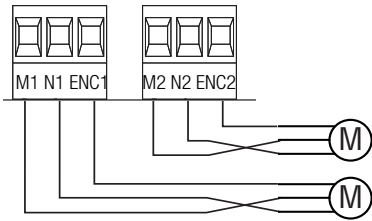

Gearmotor with encoder (**M1**) 24 V DC, delayed when closing.

Gearmotor with encoder (**M2**) 24 V DC, delayed when opening.

FINAL OPERATIONS

Fastening the covers

Once you have completed all electrical connections and commissioning, fit the covers as shown here

⚠ YOU MUST first slide the covers forward and then snap them down into place.

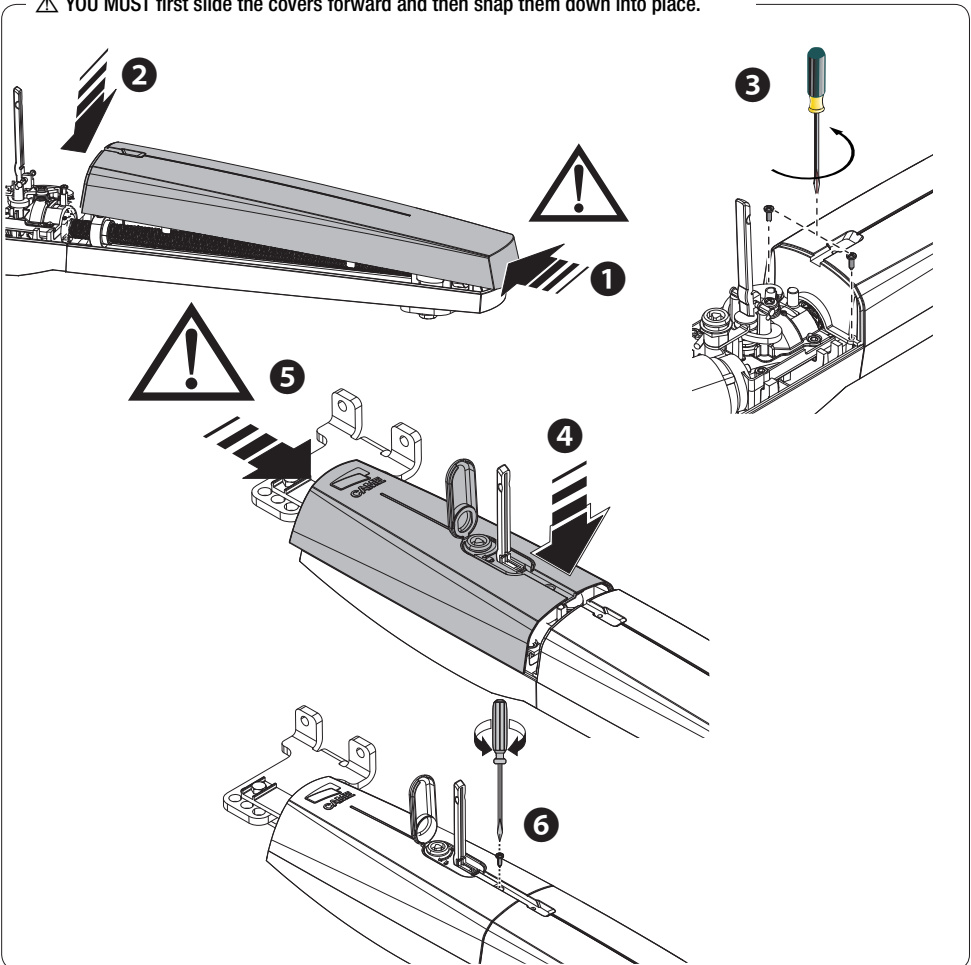

RELEASING THE GEARMOTOR

⚠ This procedure must be done with the main power cut off.

The gearmotor's manual release may cause unwanted movement of the gate, if the latter has any mechanical issues or if it is not balanced.

RELEASING

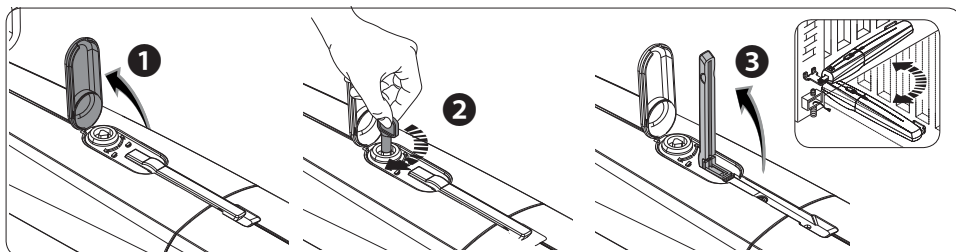

LOCKING

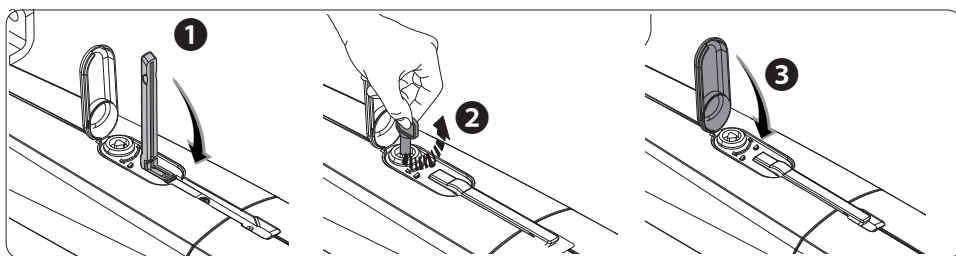

TROUBLESHOOTING

| PROBLEM | POSSIBLE CAUSES | FIXES AND REMEDIES |
|-----------------------------------|--|--|
| It neither opens nor closes | <ul style="list-style-type: none"> • Power supply is missing • The gearmotor is stuck • The transmitter's battery is run down • The transmitter is broken • The stop button is either stuck or broken • The opening/closing button or the key-switch selector is stuck | <ul style="list-style-type: none"> • Check main power supply • Call assistance • Replace the batteries • Call assistance • Call assistance • Call assistance |
| The gate opens but does not close | <ul style="list-style-type: none"> • The photocells are dirty | <ul style="list-style-type: none"> • Clean and check proper working state of photocells • Call assistance |

MAINTENANCE

Periodic maintenance

☞ Before doing any maintenance, cut off the power supply, to prevent any hazardous situations caused by accidentally activating the gearmotor.

Periodic maintenance log kept by users (every six months)

| Date | Notes | Signature |
|------|-------|-----------|
| | | |
| | | |
| | | |
| | | |
| | | |
| | | |
| | | |
| | | |
| | | |
| | | |
| | | |

Extraordinary maintenance

⚠ The following table is for logging any extraordinary maintenance jobs, repairs and improvements performed by specialized contractors.

📖 Any extraordinary maintenance jobs must be done only by specialized technicians.

Extraordinary maintenance log

| | |
|---------------------------------------|-------------------------|
| Fitter's stamp | Name of gearmotor |
| | Job performed on (date) |
| | Technician's signature |
| | Requester's signature |
| Job performed _____ _____ _____ | |

| | |
|---------------------------------------|-------------------------|
| Fitter's stamp | Name of gearmotor |
| | Job performed on (date) |
| | Technician's signature |
| | Requester's signature |
| Job performed _____ _____ _____ | |

| | |
|--|-------------------------|
| Fitter's stamp | Name of gearmotor |
| | Job performed on (date) |
| | Technician's signature |
| | Requester's signature |
| Job performed _____ _____ _____ _____ | |

DISMANTLING AND DISPOSAL

CAME S.p.A. applies a certified Environmental Management System at its premises, which is compliant with the UNI EN ISO 14001 standard to ensure the environment is safeguarded. Please continue safeguarding the environment. At CAME we consider it one of the fundamentals of our operating and market strategies. Simply follow these brief disposal guidelines:

♻️ DISPOSING OF THE PACKAGING

The packaging materials (cardboard, plastic, and so on) should be disposed of as solid urban waste, and simply separated from other waste for recycling. Always make sure you comply with local laws before dismantling and disposing of the product.

DO NOT DISPOSE OF IN NATURE!

♻️ DISMANTLING AND DISPOSAL

Our products are made of various materials. Most of these (aluminum, plastic, iron, electrical cables) are classified as solid household waste. They can be recycled by separating them before dumping at authorized city plants. Whereas other components (control boards, batteries, transmitters, and so on) may contain hazardous pollutants. These must therefore be disposed of by authorized, certified professional services. Before disposing, it is always advisable to check with the specific laws that apply in your area.

DO NOT DISPOSE OF IN NATURE!

DECLARATION OF CONFORMITY



Declaration  - CAME S.p.A. declares that this device conforms to the essential, pertinent requirements provided by directives 2006/42/EC and 2004/108/EC. An original copy is available on request.

CAME
safety & comfort





CAME S.p.A.

Via Martiri Della Libertà, 15
31030 **Dosson di Casier**
Treviso - Italy

 (+39) 0422 4940
 (+39) 0422 4941

Via Cornia, 1/b - 1/c
33079 **Sesto al Reghena**
Pordenone - Italy

 (+39) 0434 698111
 (+39) 0434 698434

www.came.com